



Wholesale Manufacturer Specializing in Tile Metal Eave Closure,
Standard Roof Flashings, and Metal Roof Systems.

DCSM Product Update

Ridge Anchor

- ***Metal component designed to mechanically fasten the hip / ridge cap on tile roof systems.***
- ***Florida HVHZ Product Approval with adhesive and mechanical attachment options.***
- ***Fabricated from 26 gauge mill finish Galvalume in 10' lengths.***
- ***Available in standard sizes of: 4", 5", 6", 7", 8"***

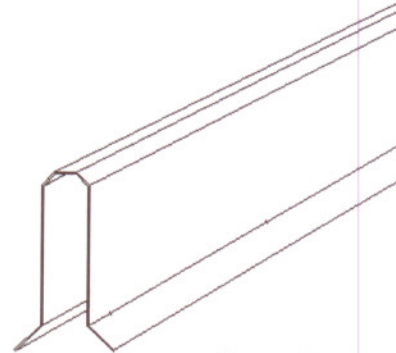

Patent Pending

DCSM Ridge Anchor Hip / Ridge Resistance Values Test Results

Tile Profile	Attachment Method	Adhesive Amount	Allowable Overturning Moment (ft-lbf)
Hip / Ridge	RT 600 / Screw	1 - 10 gram paddy under head of tile (2 - 5 gram paddies on head lap)	215
Hip / Ridge	Two Part Foam / Screw	2" x 8" paddy under tile (no foam on head lap)	198
Hip / Ridge	One Part Foam / Screw	2" x 8" paddy under tile (1" x 8" paddy on head lap)	132
Hip / Ridge	Two Part Foam (no fastener)	2" x 8" paddy under tile (no foam on head lap)	115

- **DCSM recommends the RT 600 / Screw attachment method due to the excellent uplift resistance and customer reported cost savings of over 50%.**
- **Refer to DCSM Ridge Anchor specifications for installation guidelines.**

Dan's Custom Sheet Metal, Inc. 5700 Washington Street Naples, Fl. 34109
Phone (239) 594-0530 * Fax (239) 594-2064 * Toll Free (866) 989-DCSM

**To view our complete product line visit
www.dcsm.net**

*This correspondence is intended for companies that have an Established Business Relationship with D.C.S.M. Inc.
If you have received this fax in error please call toll-free at 866-989-3276 to be removed from our database.*